

TOP VIEW

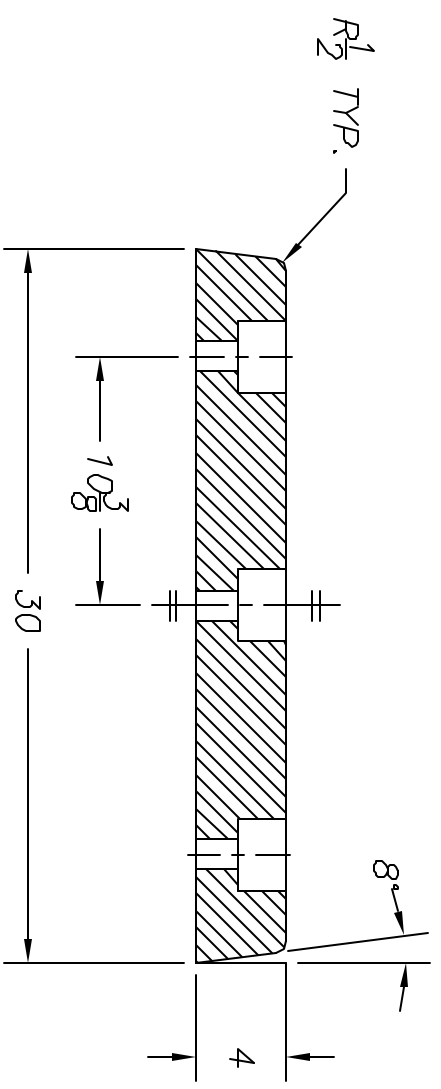

SECTION "A-A"

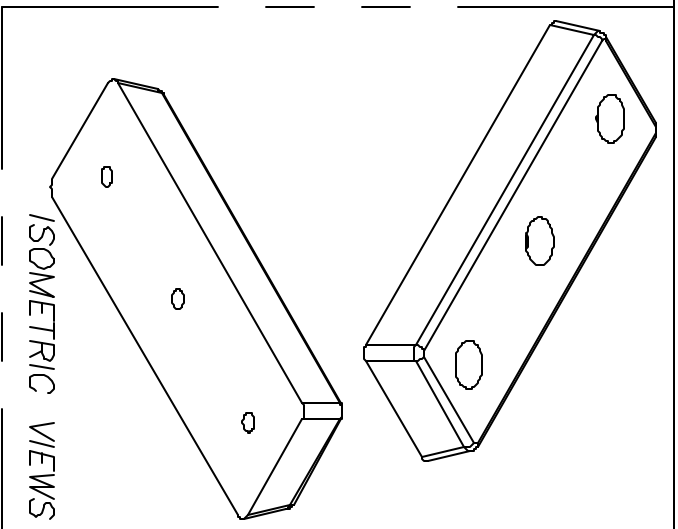

ISOMETRIC VIEWS

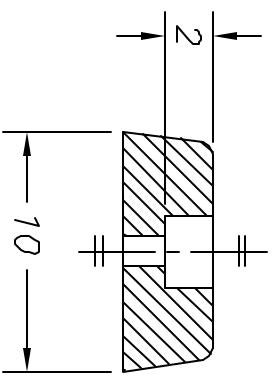

SECTION "B-B"

ESTIMATED GROSS SHIPPING WEIGHT = 47 Lbs.

NOTES:
ALL TOLERANCES ARE $\pm 1/4$ "
UNLESS OTHERWISE NOTED.

THIS DRAWING AND THE DESIGN SHOWN ARE THE PROPERTY OF TMI INCORPORATED. REPRODUCTION OR USE OF THIS DRAWING FOR ANY PURPOSE OTHER THAN THAT SPECIFIED SHALL BE VIEWED AS INFRINGEMENT AND BE SUBJECT TO LEGAL ACTION.

		TMI Incorporated 5350 Campbell's Run Road, Pittsburgh, PA 15205-9738	
SCALE:	1:8	TMI Inc. Appr.:	DATE:
DRAWN BY:	A. Iodizzo	TMI Inc. Appr.:	DATE:
TITLE	MODEL M30		
DATE:	02.2003	PART NO.	